

Be Heard, Not Seen

PSB CustomSound In-Cabinet Speaker System

CHS60 High Performance In-Cabinet Speaker

Many high-end home theater systems have most of their components, including the speakers, hidden away in cabinets. While this hides the hardware it can be detrimental to speaker performance. Understanding this, PSB pioneered the concept of purpose-designed systems for in-cabinet installations. The CHS60 joins the line up that now includes the acclaimed CHS80, an in-cabinet loudspeaker modeled after PSB's prestigious flagship Platinum T8 tower speaker and the CHS212 that is essentially a SubSonic 10 reconfigured for in-cabinet application.

The CHS60, is an in-cabinet loudspeaker modeled after PSB's prestigious Platinum T6 tower speaker. Using the components of the highly regarded T6, the CHS60 is a five driver, three way high power/high output speaker with a highly designed crossover network optimized for in-cabinet application. It delivers "Platinum-Class" performance. The CHS60 includes two crossover compensation switches to adjust for in-cabinet boundary effects or for center channel applications behind a perforated screen. The driver complement includes dual 6 1/2" high power shielded woofers with incredibly stiff woven fiberglass cones. Dual 4 1/2" midrange drivers with woven fiberglass cones are positioned in a MTM (midrange-tweeter-midrange) array around a high power, low resonance 1" titanium dome tweeter to provide superb accuracy across a broad listening window.

The enclosure construction meets Platinum-Series standards of rigidity and freedom from unwanted resonance. The system is constructed as a highly durable cabinet with a tough textured "spatter coat" matte black paint finish. It is dimensioned to fit within custom or ready-made media furniture.



CHS60 High Performance In-Cabinet Speaker

- “Platinum-Class” In-Cabinet performance
- Five Driver, 3-way system utilizes drivers of the T6
- Two crossover compensation switches adjust for in-cabinet boundary effects or for center channel applications behind a perforated screen
- Tough, textured, matte black finish

Frequency Range (-6dB):	38-21,000Hz
Recommended Power:	80-300 Watts
Impedance:	4 Ohms
Sensitivity (1W (2.83V) @1m)	
Anechoic Chamber:	87dB SPL
Typical Listening Room:	89dB SPL
Drivers:	2 x 6 1/2" Woofers, 2 x 3 1/2" Midranges, 1" Tweeter
Dimensions (W x H x D):	15 x 20 x 11 1/8" (grille on) 15 x 20 x 10 1/2" (grille off)

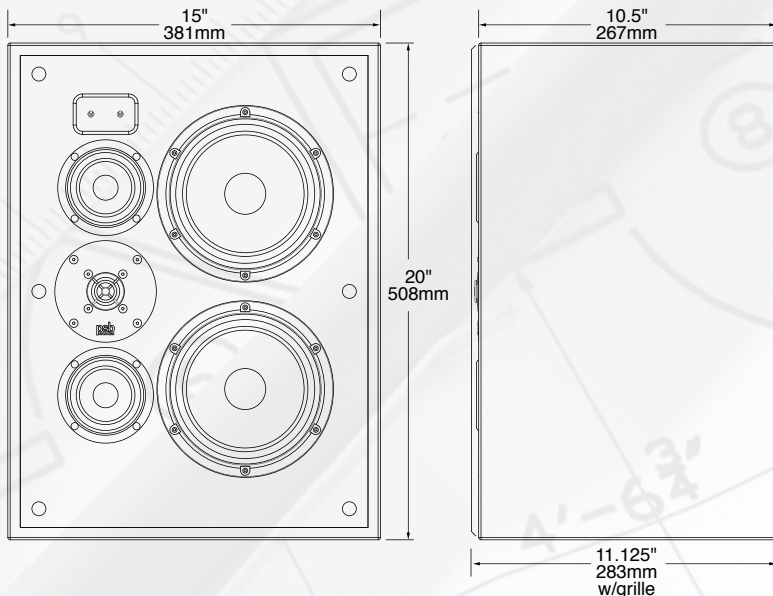

Note: Depth dimensions exclude rear speaker connectors.
Add 1" plus required wire spacing.

Installation Notes

- Try to install the systems at a height equal to ear level when seated.
- The Midrange/Tweeter/Midrange array should be vertical.
- Left to Right Speaker span defines stereo stage width. Typically should be wider than screen.
- Open volume in equipment cabinet surrounding the CHS80 (CHS60) should be lightly filled with fiberglass or acoustical foam to reduce cavity resonance.
- Don't recess the system any farther into cabinet than necessary.
- Confirm that media center grille frames do not block sound to any listener, especially of midranges or tweeter.
- Boundary switch deals with overly "rich" midrange when cabinet mounted.
- "Screen Perforation" switch has a strong effect and should only be used when the system is mounted behind a perforated screen.
- See manual for more installation hints.

To Reach US Customer Service dial 1 888 772 0000 ext 4445 or 4342